

AIR WINCH

TAW-300B

TAW-500

TAW-1000

TAW-1500A

TAW-2000

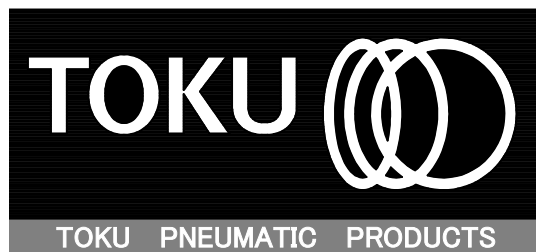

www.air-allied.com.au

MANUAL

INSTRUCTION MANUAL

Carefully read all instructions before operating
Or servicing any TOKU tools.

Air & Allied Sales (Pacific) Pty Ltd
Head Office: 1/50 Success Street, Acacia Ridge, Brisbane, Queensland, Australia 4110

TOKU PNEUMATIC CO., LTD.

14-04

No.3

INTRODUCTION

Thank you for purchasing the Toku Air Winch.

This manual is a guide which will show you how to use the Air Winch safely and efficiently. Please read the manual in its entirety and understand the contents before proceeding to operate the Air Winch. Also convey this information to the actual operators of the winch.

The Air Winch was designed to operate on compressed air to pull or lift loads. As a result before operating the Air Winch, it is necessary to also read the instruction manual for the compressor. In addition, for proper regulations about usage of the Air Winch, consult the “ Crane safety regulations standards “ Usage other than the ones written in this manual should be performed safely and with responsibility.

Before reading the manual it is important to understand the following terms. Precautions concerning safety, the following points should be obeyed.

PLEASE UNDERSTAND THE FOLLOWING POINTS BEFORE READING THIS MANUAL;

- ◆ With regards to the safety precautions, the following words are used to identify safety messages in the manual.
 - ⚠ WARNING; This word is used on safety messages and labels where a potential dangerous situation could result in serious injury or death if the hazard is not avoided.
 - ⚠ CAUTION; This word is used in safety messages and on labels for hazards which could result in minor or moderate injury if the hazard is not avoided. This word may indicate hazards whose result could be damage to the equipment. Please also note a caution mark can lead to serious injury depending on the situation.
- ◆ Store this manual nearby and read it over continuously.
- ◆ If this manual is damaged or is lost, immediately contact your dealer to have it replaced.
- ◆ If the winch is used by more than one person, please have the new person read this manual before operating the winch.
- ◆ If the winch is transferred to another location, please make sure this manual is read by the next operator/owner.
(Please note this manual contains general information about Precautions in operating the purchased item, as a result some diagrams may not relate to the product.)

If you have any questions about the winch or the instruction manual, please contact:

Air & Allied Sales (Pacific) Pty Ltd

CONTENTS

	Page
Introduction.....	1
Contents.....	2
Precautions concerning safety.....	3
Precautions during operation.....	5
Basic Precautions.....	6
Specifications.....	7
Description of Parts.....	7
Preparation before operation.....	8
Before Operation.....	1 1
How to Operation.....	1 4
Maintenance and Inspection.....	1 6
Trouble shooting.....	1 7

PRECAUTIONS CONCERNING SAFETY

 **WARNING:**

- When operating the Air Winch, obey the safety precautions stated in this manual.

 **WARNING:** Obey facility safety rules

- Operators who use the Air Winch must have training.
- Obey all facility rules, safety precautions and operational regulations.
- When operating the Air Winch jointly with a partner, make sure proper signals are agreed upon before operating.

 **WARNING:** Wear proper clothing and safety equipment

- Wear proper clothing during operation of the Air Winch.
- Do not forget to wear a Helmet, safety boots and gloves when operating the Air Winch. If the Noise level is high, it is necessary to wear ear protectors.
- Do not operate the Air Winch while wearing a tie or with open sleeves. It is possible that these loose items may get rolled in with the cable or rope.

 **WARNING:** Safe operation starts from a stable position

- Do not operate the Air Winch in an unstable position. Always have good footing and a stable base when operating the Air Winch.

 **WARNING:** Install hose and rope securely

- Make sure the rope is securely attached to the drum and clamped. Always keep a minimum of 3 turns of rope left on the drum for safety. (To prevent the rope from removing from the drum.)

 **WARNING:** Do not modify the Air Winch

- Do not remove screws or covers which are on the Air Winch.
- Do not modify and operate the Air Winch. It is a very dangerous practice. The manufacture will not take any responsibility if a unit has been modified and an accident results from the modification.

 **WARNING:** Do not use the rope or equipment as earth (ground)

- When performing welding operations, do not use the rope or Air Winch as ground or earth. This may become the cause of an accident or breakage of the Air Winch.

⚠ WARNING; Mount the Air Winch securely to the platform. And also secure using bolts

- If the Air Winch is not securely attached to the platform with bolts, and the attachment loosens, it will lead to major damages of the Air Winch and also will cause a fatal accident.

⚠ WARNING; Do not use the Air Winch as a lifting device for people

- The Air Winch is to pull or lift loads. Never lift or pull people using the Air Winch.

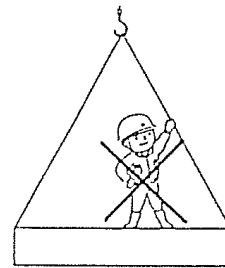

⚠ WARNING; Do not leave the site when using the Air Winch

- Do not leave the job site when a load is on the Air Winch. Always remove the load before leaving the site.

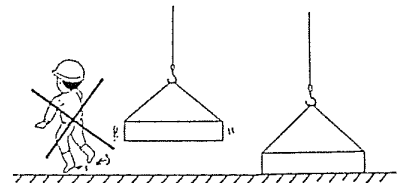

⚠ WARNING; When a load is lifted stay away from the load

- When the load is lifted stay a minimum of 5 meter away from the lifted load.

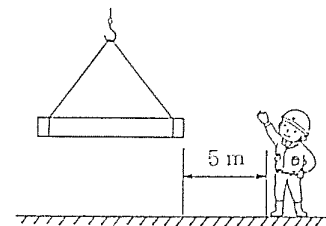

⚠ WARNING; Balance the load

- When using wire or a sling, make sure the load is balanced before lifting.

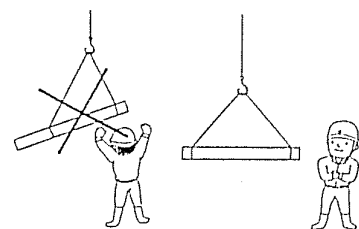

⚠ WARNING; Do not lift or lower the load suddenly

- Do not lift or lower the load suddenly. The load may lose its balance and may cause an accident. Also it may lead to breakage of the Air Winch as well and the rope/wire.

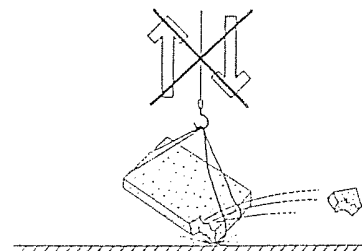

PRECAUTIONS DURING OPERATION

 **CAUTION;** Confirm signals when using the Air Winch with a partner.

When operating the Air Winch with a partner, make sure to confirm signals for safe operation. Always obey the safety rules.

 **CAUTION;** Do not handle the operating switch when not necessary.

Do not operate the Air Winch until preparation is performed for lifting. This may lead to un-safe preparation of the load and cause an accident.

 **CAUTION;** Do not over load the Air Winch.

Before operating the Air Winch make sure the load is within the rated load of the Air Winch being used. Also, when pulling the load side ways, confirm the tensile strength of the rope before proceeding.

 **CAUTION;** Do not over wind or proceed past the final 3 winds on the drum.

Over winding may result in override of rope from the drum.

Proceeding past the final 3 winds on the drum may lead to wire/rope override from the drum.

If the rope falls from the drum it will cause a sudden shock to the load increasing the tension on the wire/rope. It will also lead to an over load to the Air Winch causing a possible accident.

Make sure the portion of the wire/rope which is connected to the drum is not directly holding the load. It will release if the weight of the rated load is put on the connector. As a result it is absolutely necessary to have a minimum of 3 winds of rope on the drum at all times.

 **WARNING;** Do not turn “clutch handle” OFF while loading material.

- This air winch is equipped with a “Clutch” to link the air motor and drum and to release the air motor and drum. If this “clutch handle” is set-off while loading any material, the drum is set free, and it might cause an accident of dropping load material after the rope is rapidly wound off by the tension of the wire rope.

BASIC PRECAUTIONS

 **CAUTION;** Keeping the area tidy is the first step to safety.

- Keeping the job site tidy is the first step to a safe environment.
- Keep the facility clean and neat at all times.

 **CAUTION;** Stay away from the job site if you are not operating the Air Winch.

- If you are not the operator, stay away from the job site, especially children.

 **CAUTION;** Difficult operations will lead to accidents.

- Do not use the Air Winch for operations over its capacity. These operations may lead to damage to the Air Winch and should be avoided.

 **CAUTION;** Stop operating the Air Winch if trouble is detected.

- When operating the Air Winch, if trouble is found, immediately stop operating the Air Winch and inspect or repair.

 **CAUTION;** Handle the Air Winch with care.

- Do not drop or hit the Air Winch externally. This will lead to cracks and damage the Air Winch. Also do not stamp or engrave information directly onto the Air Winch. If a crack develops, and air leaks through this crack, do not operate the Air Winch.

 **CAUTION;** Good maintenance will extend the life of the Air Winch.

- Keep a good maintenance program for the Air Winch and keep it clean.

 **CAUTION;** Periodic inspection of the Air Winch is basic safety.

- Periodic inspection of the Air Winch will allow your Air Winch to operate smoothly and safely. Refer to the crane safety standards. Daily and monthly inspection programs should be performed.

 **CAUTION;** For inspection or repair of the Air Winch, consult your dealer.

- Contact your dealer for repairs or inspection of the Air Winch. When parts need to be replaced, use only genuine TOKU parts.

 **CAUTION;** Storage of the Air Winch is also very important

- Store the Air Winch away from children in a dry area. When storing the Air Winch for a longer period of time, to prevent internal rust, apply 5 cc of lubrication into the air hose and operate the hoist for 5 seconds.

SPECIFICATIONS

Model	Rated Load (Kgf)	Wire rope Dimensions (mm x m)	Rope Speed (m/min)	Air Consumption (m ³ /min)	Weight (Kg)	Air Supply Inlet Size (Inch)	Mounting Bolts (Size x Q'ty)
TAW-300B	300	6 x 37	27	3.4	42	Rc 3/4	M10 x 4
TAW-500	500	8 x 61	20	3.4	75	Rc 3/4	M12 x 4
TAW-1000	1000	10 x 91	11.5	3.9	90	Rc 3/4	M12 x 6
TAW-1500A	1500	12 x 60	8.5	4.1	90	Rc 3/4	M12 x 6
TAW-2000	2000	16 x 45	5.7	4.9	130	Rc 3/4	M12 x 6

- ※ Conditions for speed and air consumption in above specification: Air pressure 0.6MPa, Winding lated load, and winding 1st layer of drum.
- ※ Winding performance and air consumption fluctuates depend on operating air pressure, layers of wind, winding load etc.

DESCRIPTION OF PARTS

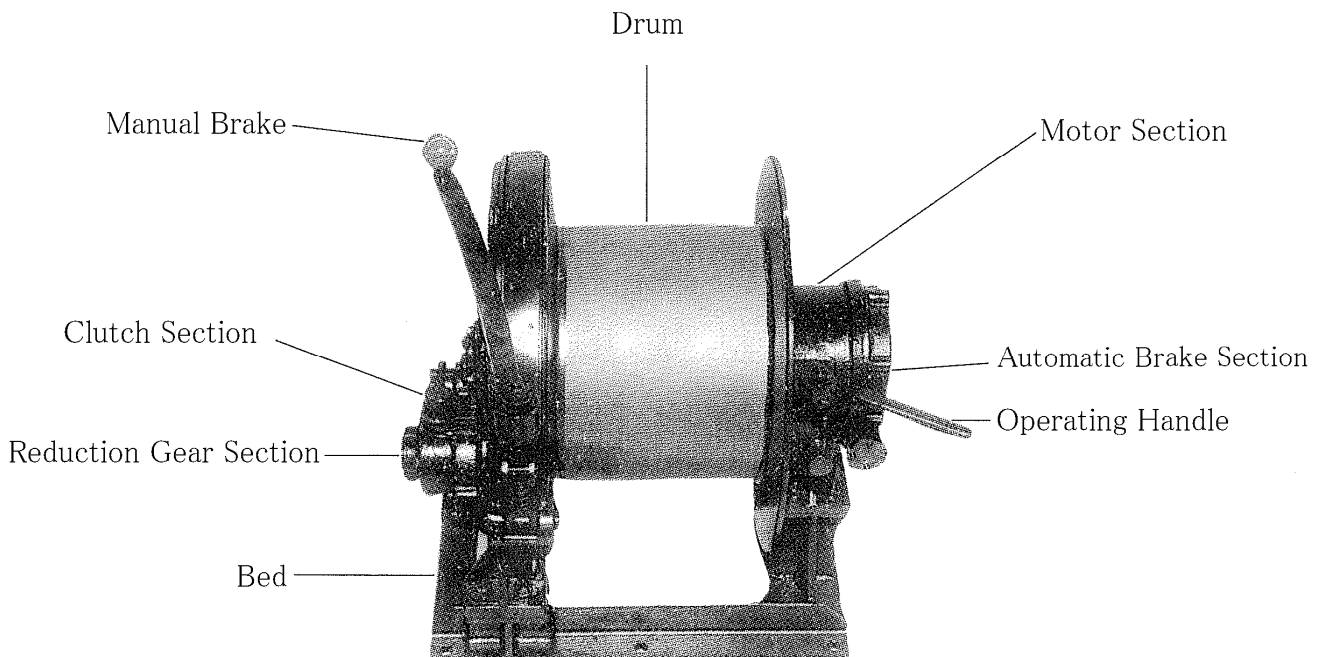

PREPARATION BEFORE OPERATION

1. Selection of a compressor and method of draining the system.

- Method of selection; (Please refer to the specification chart to see the air consumption for each model.)

$$\text{(Air Consumption } \times 10 \text{) } \times \text{ No. of units } \leq \text{ Horse Power of Compressor}$$

- Method of Draining the system;

If water or oil accumulates inside the system, this will result in rust and eventually cause damage or a breakdown. Before using the equipment, loosening the drain plug which is located at the bottom of the tank on the compressor and drain the accumulated water/moisture or oil. Make sure clean dry air is used. (For details and instructions refer to the Compressor Instruction manual.)

2. Piping

- ⚠ **CAUTION;** Install an air filter, regulator and line oiler near the air winch.

Size; 1B(25mm) is recommended. (To assure performance)

- ⚠ **CAUTION;** Install a drain in the lowest area in your piping and drain the system regularly.

If the air contains a lot of moisture or water, it may cause the silencer on the Air Winch to freeze. Also it may lead to a breakdown due to rust developing inside the Air Winch.

3. Preparation of Hose and connection

• Size of Hose;

The hose should have an inside diameter of 19mm.

⚠ CAUTION; If the hose length is too long, this will result in reduction in air pressure and reduce the power.

Please refer to the chart below concerning the reduction in air pressure.

Hose Dimensions (mm)	Air Pressure (MPa)	Total length of hose; 10 Meters free air flow (m ³ /min)						
		1.50	2.00	2.50	3.00	3.50	4.00	4.50
19	0.4	0.0122	0.0216	0.0339	0.0447	0.0643	0.0840	0.1062
	0.5	0.0106	0.0180	0.0282	0.0407	0.0536	0.0700	0.0886
	0.6	0.0091	0.0156	0.0243	0.0348	0.0460	0.0600	0.0760
	0.7	0.0079	0.0141	0.0213	0.0306	0.0402	0.0525	0.0664
25.4	0.4	0.0031	0.0055	0.0083	0.0121	0.0137	0.0189	0.0239
	0.5	0.0026	0.0047	0.0069	0.0101	0.0121	0.0158	0.0200
	0.6	0.0026	0.0040	0.0059	0.0081	0.0104	0.0135	0.0172
	0.7	0.0020	0.0035	0.0053	0.0076	0.0090	0.0119	0.0150

(MPa)

※ Above table shows the volume of pressure loss at each air pressure level and volume. The secondary air pressure at the hose outlet port is the volume deducted each volume of pressure loss from the air pressure at the hose inlet port.

※ If the hose length is longer than 10m, the hose length and volume of pressure loss are proportionally related. If the hose length is 20m, the volume of pressure loss is double the volume on the above chart.

4. Inspection of Wire Rope.

⚠ CAUTION; Do not use a Wire Rope which has a kink or is deformed.

(See sketch to the right) Do not use a wire rope which has broken strands. This will result in serious injury or accident.

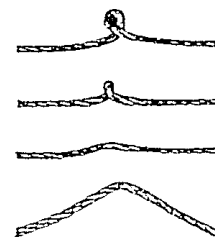

5. Confirmation of the strength of mounting location.

⚠ WARNING:

- Before mounting the air winch, confirm the strength of the mounting location if it meets the sufficient safety rate to hold the body and rated capacity.
If above condition is not met, do not mount the winch.

6. Mounting the Air Winch.

⚠ WARNING: Mount the winch securely

Make sure the Air Winch Bed and the assembly base is fastened using bolts and the bolt quantity meets regulation.

Bolt or Nut fastening Torque;

Model	Fastening torque
TAW-300B	25 N·m
TAW-500	40 N·m
TAW-1000	40 N·m
TAW-1500A	40 N·m
TAW-2000	40 N·m

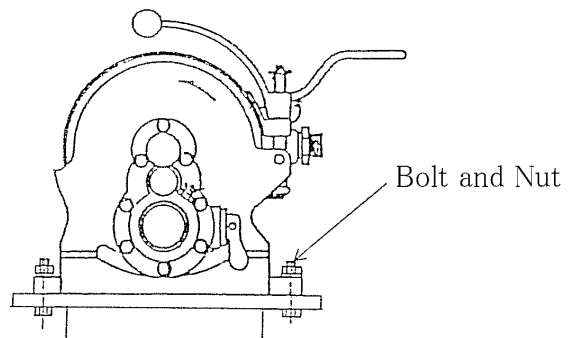

7. Connecting the Air Winch

⚠ CAUTION:

Before connecting the air hose to the Air Winch, always blow flush the air inlet area. This will prevent any foreign substances from entering the Air Winch.

⚠ CAUTION:

Before connecting the air hose to the Air Winch, apply about 5 cc Lubrication into the Inlet port of the Air Winch. This will provide the initial lubrication to the Air Motor.

After the above procedures are completed, attached the air hose to the Air Winch.

BEFORE OPERATION

1. Remove the cap of the exhaust port



WARNING:

In the case of a brand new winch, the cap is attached on the exhaust port when shipped from the factory.(except TAW-300B)

Please remove this cap, otherwise, the winch will not operate.

Depending on conditions, this cap might blow off and lead to an accident.

2. Turn clutch handle on

This air winch is equipped with a "Clutch" to link the air motor and drum(ON) and to release the air motor and drum(OFF).

This clutch is controlled by Clutch handle.

Please turn this handle ON as shown in the drawing to the Right, this will connect the air motor and drum. In the OFF position the air motor runs idle and drum will not operate.

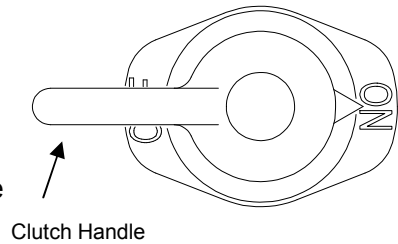

3. Check Operation Air Pressure



CAUTION: The operating air pressure is 0.4-0.6 MPa

If the air pressure is below 0.4MPa or exceeds 0.6MPa, this will effect the performance, shorten the life of parts or will become a safety hazard. It is necessary to keep good consideration concerning the pressure, volume and piping for the compressor being used.

4. Lubrication



CAUTION:

- Lubrication to the motor is performed through the line oiler installed into the piping. Oil flow to the motor should be 10-15 drops/min.
- The reduction gears should be greased once every month using a grease gun. When the gear box is dis-assembled, the grease should be changed.
- Apply lubrication to the wire rope. This should be performed periodically.

Lubrication Oil

Oil	Grade	Application	Lubricating method
Additive Turbine oil	ISOVG32-46	Air motor part	Line oiler
Lithium grease	NLGINo.2	Rope, Gear	Apply to rope and gear case

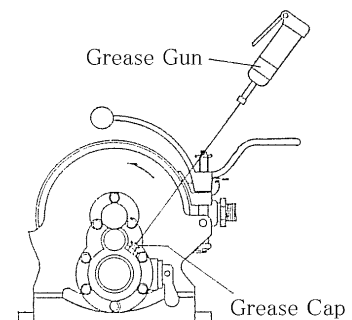

5. Connecting the Wire Rope to the Drum

⚠ CAUTION; Make sure the wire end is secured firmly.

The end of the wire rope must be securely fastened to the fastening point on the winch drum. After inserting the wire end into the hole, refer to the following chart to fasten the bolt.

Model	Bolt Size	Fastening Torque
TAW-300B	M8	25 N·m
TAW-500	M8	25 N·m
TAW-1000	M12	60 N·m
TAW-1500A	M12	60 N·m
TAW-2000	M16	120 N·m



Set screw (2pcs)

⚠ WARNING;
Please confirm that the direction of the Wire Rope is in the direction of the Arrow as shown in the drawing to the right.

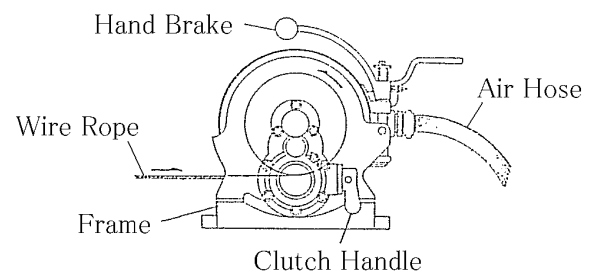

Operate the winch with the wire turning between the Drum and the Winch frame. Otherwise, the excessive load will be put on the winch and become the cause of an accident.

⚠ WARNING:

The Fleet Angle (θ) for the wire rope and drum should be within 2 degrees.

If the fleet angle exceeds 2 degrees this will lead to wire falling off the drum, as a result leading to abnormal wear and become the cause of an accident.

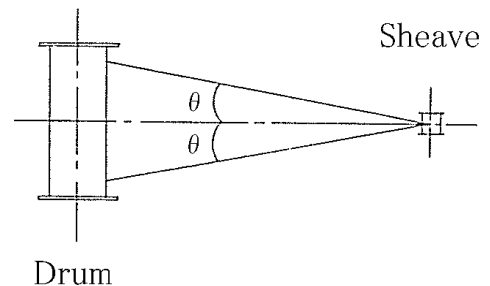

6. Test Operation:

Winding and Un-winding operation

⚠ WARNING:

Please review the relationship of the un-winding length for the wire rope checking the time to un-wind. In this case make sure 3 winds on the drum is maintained at all times.

Also, do not over wind the drum since the wire will over ride the drum walls.

Checking the Wire Rope:

⚠ CAUTION:

As shown on page 9, make sure the wire rope is not deformed. Also check slings and other attachment devices before usage.

7.

Re-confirmation

⚠ WARNING:

Before using slings, wire ropes, sling chains or hooks, always check the rated load, and also check for damages before usage. It is very dangerous if not checked properly.

HOW TO OPERATE

1. Confirmation of clutch

Confirm if the clutch which connects air motor and drum is "ON" as explained in the previous page.

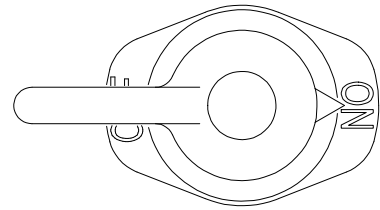

Clutch is ON

2. Release of Handle brake

Release the Handle brake before operating.

This air winch is equipped with an Automatic brake that connects the air motor separately from the Hand brake.

So, when any material is loaded, the wire rope cannot wind off due to this auto brake system even if the hand brake is released.

* The condition is that the Clutch which connects the air motor and drum is ON.

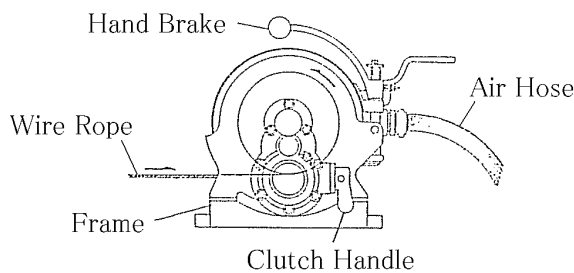

3. Operating and Stop

Following the instructions below, the direction of the operating handle for "winding off" and "winding roll" wire rope. Once the handle is released, the winch will stop.

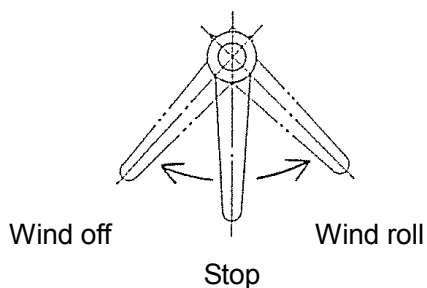

TAW-500~2000

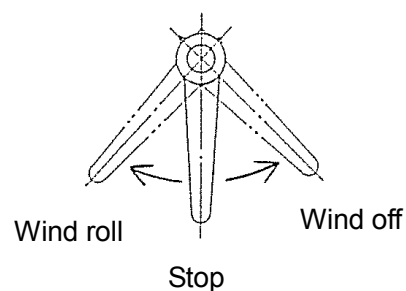

TAW-300B

4. Speed control for winding roll and winding off

You can fine adjust the speed of winding the roll and winding off by operating handle.

If you move the handle in small increments, the speed will be slow, and if you move the handle in larger increments, the speed will increase. You can adjust the speed with single step.

5. Lifting and lowering load

- ① Set the load to the wire rope in a well-balanced position
- ② Wind roll with slow speed until the wire rope tightens and stop the winch operation to hold.

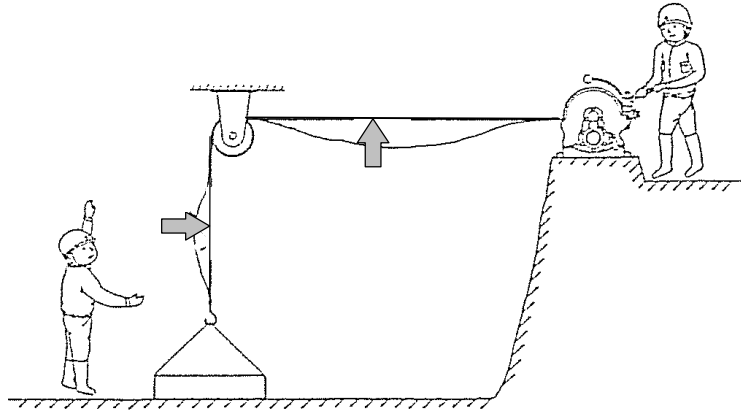

- ③ Check if the load is connected to the wire rope securely and has not slipped.
- ④ Wind roll a little at slow speed first, then wind roll at the speed needed if there is no problem.
- ⑤ Make sure the landing site for the load is stable and safe. Then, lower the load at slow speed.

6. Apply the Hand Brake

Although this hoist is equipped with an Automatic brake which is connected to the air motor, for safety reasons, please apply the hand brake by tightening it clockwise when you stop the loading operation of the material.

MAINTENANCE AND INSPECTION

⚠ WARNING:

- To operate the hoist safely, it is necessary to inspect the hoist regularly. When the hoist is in use, obey the regulations in the crane safety standards and perform the following inspections.

★DAILY INSPECTION

1. Inspection of Air pressure and Oil.

Confirm that the hoist is operating between 0.4-0.6 MPa air pressure. Also make sure the line oiler is operating correctly. If oil does not get to the motor, this will lead to early wear of the motor parts.

2. Inspection of the Wire Rope

Check the wire rope for the following;

Is the wire rope lubricated.

Is there signs of rust on the wire rope.

Are there any strands broken.

If the wire rope is not lubricated properly, this will lead to premature wear of the wire.

3. Does the Air Winch operate smoothly without abnormal sounds?

Stop the Air Winch if you hear any abnormal sounds when the Air Winch is operating.

★MONTHLY INSPECTION

1. Check the wire rope

Check the wire rope for damage or broken strands. If a problem is seen, the wire rope should be replaced.

2. Check Operation of the brake.

Check the operation of the brake. If the rated load slowly moves down, the operation of the Air Winch should be stopped and the Brake adjustment screw should be adjusted clockwise. If it is not possible to adjust, the brake band has worn out and it is necessary to change this part.

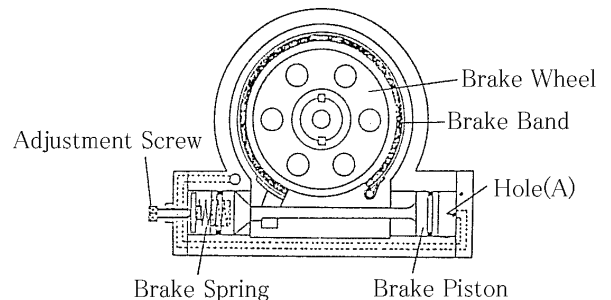

3. Check for loose bolts, rust, paint removal or other damaged areas. If any of these problems are seen, repairs should be performed immediately.

★ANNUAL INSPECTION

1. The Air Winch should be dis-assembled and inspected once a year. (For details contact your dealer or distributor.)
2. For repairs, contact your dealer or distributor.

★STORAGE

1. Remove all debris or dirt from the Air Winch.
2. After using the Air Winch in order to prevent rust build up, apply about 50 cc of lubricating oil into the inlet of the Air Winch and operate for about 5 seconds.
3. To prevent dirt or debris from entering the inlet of the Air Winch, apply a plug before storage.
4. To prevent rust, store the hoist in a dry place.

TROUBLE SHOOTING

 **WARNING** ; If the Air Winch needs to be dis-assembled and repaired, please bring the Air Winch to a service shop or the dealer.

ITEM	CAUSE	COUNTERMEASURE
Not enough power to wind	* Not enough air pressure	* Check air supply
	* Friction in air hose	* Select new size hose
	* Vane wear	* Replace parts
	* Not enough lubrication	* Check exhaust for lubrication
	* Brake is not open fully	* Check air pressure, air leakage or rust.
Does not operate	* Foreign matter in motor	* Dis-assemble and clean
	* Brake is not open fully	* Replace brake piston o-ring
		* Brake release hole is plugged
	* Rust in automatic brake	* Dis-assemble and repair
	* No air supply	* Bent hose and check valve
Air is leaking	* Breakage of o-ring, packings	* Replace parts

CUSTOMER MEMO

Record information such as the distributor name, model number and serial number.
It will be of good use when you bring the unit in for servicing.

Date of Purchase	Distributor Name
Model	
Serial Number	

This is a high precision manufactured product. As a result if the unit does not work Operate properly do not attempt to repair the unit. Contact our distributor Air & Allied Sales (Pacific) Pty Ltd. Also, if parts are needed or if you have any questions about how the unit works, please do not hesitate to contact Air & Allied Sales (Pacific) Pty Ltd.